

BLU-BOARD

High density extruded polystyrene insulation board



CC Technique Product Data Sheet

Edition: December 2015

Division: 7

Thermal & Protection

■ The Product

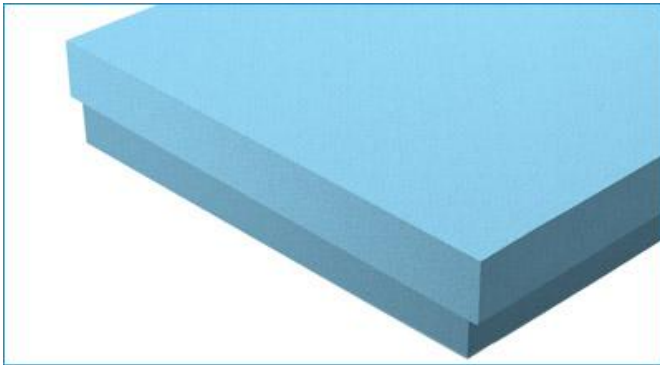

BLU-BOARD thermal insulation is a high density, rigid, extruded polystyrene insulation board.

It has a 100% closed cell structure and is produced on a fully automated extrusion process in accordance with international standard and specifications

This process will guarantee unique properties such as high compressive strength, excellent resistance to the diffusion of water vapor and water absorption, long term performance and high insulation value. Blu-Board requires no thermal barrier over a metal deck.

■ Application

- Industrial - residential - commercial single ply roofing systems [ballasted, mechanically attached, fully adhered]
- Inverted roofing system insulation.
- Agricultural mushroom farms, fish farms, wineries etc...
- Interior and exterior wall insulation.
- Sandwich panels insulation
- Insulation under roads / railways / airport runways and suspended concrete slabs
- Cold storage floor and wall insulation.
- Refrigerated trucks for roads and rails
- Under Ground foundation and walls Insulation
- Roof garden insulation

■ Advantages

- Closed and uniform cell structure
- Uniform density distribution
- Good dimensional stability
- Low moisture absorption
- High resistance to heat flow i.e. conductivity
- High ageing resistance
- Long term performance
- Meets requirements of ASTM C 578.

■ INVERTED ROOF SYSTEM

The inverted roof concept, which is also known as protected membrane or upside down roofing, succeeds in insulating both the weather-proofing membrane and the R.C slab from extreme thermal stresses. This is achieved by inverting the arrangement of the thermal insulation and the waterproofing membrane and by placing BLU-BOARD extruded polystyrene thermal insulation board above, instead of below, the waterproofing membrane.

This concept is very simple to apply with minimum labor requirements and is very effective in protecting the waterproofing membrane.

■ Application

The membrane should be applied over a clean and smooth deck surface.

Each BLU-BORD panel is loosely laid over the waterproofing membrane. With tight staggered joints.

Gravel or pavers should be applied loose laid over the BLU-BOARD panels to protect it from wind uplift and UV radiation. The membrane should not include solvents which could attack the BLU-BOARD extruded polystyrene foam.

■ Panel characteristics

Available in 49.2"x23.6" [1250mm x 600mm]

■ Thermal properties

The ability of insulation to resist heat flow is usually the principal consideration in comparing insulations. The materials resistance to heat flow is expressed by its R-value the greater the insulating power.

BLU-BOARD rigid thermal insulation board's performance is essential for the proper design of a building's air conditioning systems and heating as well as for its ability to assist with moisture management. Buildings are kept cooler inside when it is hot outside and warmer when it is cold.

BLU-BOARD rigid thermal insulation board will help customers save energy and money while improving the comfort of those inside and the durability of the building structure. Residential and commercial buildings are faced with many choices when it comes to selecting the most effective form of insulation for roofs, wall or foundations.

BLU-BOARD rigid thermal insulation board maintains its excellent insulating power over time when compared to other insulation products is second-to-none.

■ Thermal resistance & mechanical properties

The superior moisture resistance of BLU-BOARD rigid thermal insulation board provides outstanding benefits for most construction and engineering applications.

Fortunately, BLU-BOARD rigid thermal insulation board's superior moisture resistance is well established. Not only is polystyrene naturally hydrophobic [no chemical affinity for water]

But its fine closed-cell structure and smooth continuous skin helps the foam resist moisture better than other types of insulating materials.

BLU-BOARD is easy to handle and available in a variety of sizes and compressive strengths to suit various application requirements.

These and other characteristics also make BLU-BOARD rigid thermal insulation board the proven product choice for below grade insulation. It can be installed under the roof-membrane.

Conventional system or over the membrane [inverted system] to protect it from damage and weather, parking decks. Underground storage tanks and a number of special insulation applications.

■ Chemical resistance & soil compatibility

BLU-BOARD rigid thermal insulation board is recognized as a stable extruded polystyrene foam product and is resistant to many common chemicals such as: acids, bases, water and water-based paints, alcohol and alcohol-based paints, brine or salt water, cement and mortars, asphalts etc... avoid foam contact with consideration of solvents, chlorinated hydrocarbons gasoline and fuel oil.

BLU-BOARD rigid thermal insulation board is an affected by substances normally found in soil] I.E acids, alkalis, bacteria, etc...

It will not corrode, rot, or support the growth of mold mildew or soil microorganisms. It has no food value and it will not support plant or animal life .BLU-BOARD rigid thermal insulation board will last the life of most buildings in which it is used provided it does not suffer from physical damage.

■ Outdoor exposure & storage

BLU-BOARD rigid thermal insulation board is not affected by the weather and may be stored outside. Prolonged exposure to UV radiation in sunlight may cause the surface to become pale and dusty. This will have no significant effect on insulating value unless the surface is eroded, thickness is reduced.

A protected covering with a bright color should be used for extended outdoor exposure periods.

BLU-BOARD rigid thermal insulation board has an excellent dimensional stability; it is not affected by high temperature, humidity or direct sunlight.

■ Combustion precautions

Like many construction materials BLU-BOARD rigid thermal insulation board is combustible and may constitute a fire hazard if improperly installed. Although BLU-BOARD rigid thermal insulation board contains a flame retardant additive to inhibit ignition from small fire sources, it should not be exposed to open flame or other ignition sources during shipping, storage, installation or use.

■ Inverted roof system application

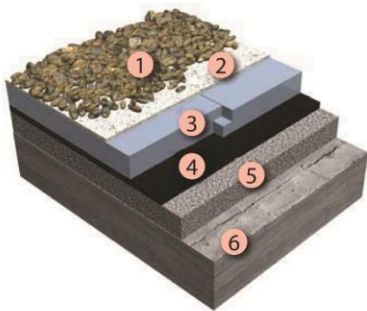

- 1- Gravel
- 2- Separation Layer
- 3- Sure roof
- 4- Waterproofing membrane
- 5- Screed to slope
- 6- Concrete deck

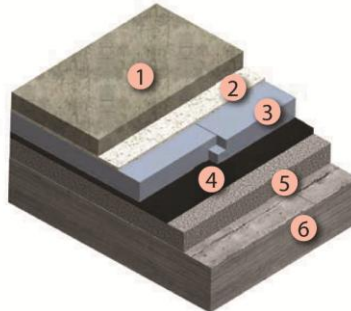

- 1- Cast in situ concrete
- 2- Separation layer
- 3- Sure roof
- 4- Waterproofing membrane
- 5- Screed to slope
- 6- Concrete deck

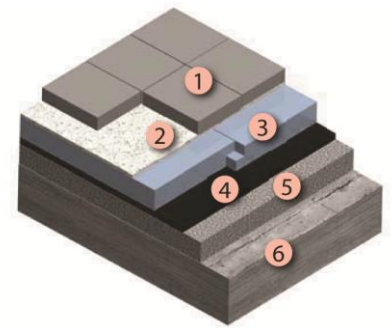

- 1- Concrete pavers
- 2- Separation layer
- 3- Sure roof
- 4- Waterproofing membrane
- 5- Screed to slope
- 6- Concrete deck

■ Moisture resistance & chemical properties

Dimensional stability is a measurement of a material's change in dimensions length, width and thickness, in response to various environmental exposure conditions. The standard exposure conditions are usually elevated temperatures at both ambient and high relative humidity levels. Temperatures at both ambient and high relative humidity levels.

■ Warm roof system

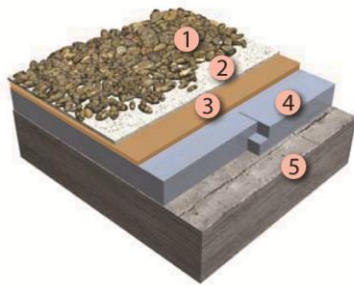

- 1- Gravel
- 2- Separation layer
- 3- Single-ply membrane
- 4- Sure-roof
- 5- Concrete deck

■ Floor insulation system

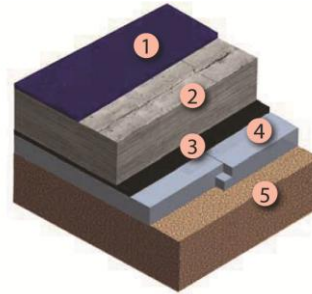

- 1- Floor finish
- 2- Concrete slab
- 3- Vapor barrier membrane
- 4- Sure roof
- 5- Soil [well compact]

Code	Description	Unit Of Sale	Base Unit	Color
KP34020	XPS extruded polystyrene [1.25m*0.6m*2cm]	Board	m ³	Blue
KP34025	XPS extruded polystyrene [1.25m*0.6m*2.5cm]	Board	m ³	Blue
KP34030	XPS extruded polystyrene [1.25m*0.6m*3cm]	Board	m ³	Blue
KP34040	XPS extruded polystyrene [1.25m*0.6m*4cm]	Board	m ³	Blue
KP34050	XPS extruded polystyrene [1.25m*0.6m*5cm]	Board	m ³	Blue

■ Physical properties

Property	Standard	units	Average value	Average value	Average value	Average value
Density	DIN 53420 ASTM D 1622	Kg/m ³	26-28	32-35	38-42	45-48
		lbs/ft ³	1.6-1.7	2.0-2.2	2.4-2.6	2.8-3.0
Thermal conductivity laboratory value at 10°C (50° F)	ASTM C 177 Or ASTM C 518	w/m.k	0.029	0.028	0.026	0.026
		Btu.in/ft ² hr °F	0.21	0.2	0.18	0.18
Thermal conductivity @ 24°C[75°F] mean temp	ASTM C 177 ASTM C 518	w/m.k	0.032	0.032	0.030	0.030
		Btu.in/ft ² hr.°F	0.220	0.220	0.210	0.210
Compressive strength @ 10% deflection	DIN 53421 ASTM D1621	Kpa	200-210	250-410	500-700	700
		psi	29-31	35 - 60	70-100	100
Water vapor diffusion resistance factor	DIN 52615	μ	100-225	100-225	100-225	100-225

Property	Standard	units	Average value	Average value	Average value	Average value
Water vapor permeability	ASTM C 355	Perm. inch	0.5	0.4-0.6	0.4-0.6	0.4-0.6
Water absorption by submersion	DIN 53428	% by Vol	0.20	0.20	0.20	0.20
Water absorption by submersion	ASTM D 2842 } 1% by Vol. precision	% by Vol	1.00	1.00	1.00	1.00
Capillarity			None	None	None	None
Linear coefficient of thermal expansion and contraction		°C -1	70.10-6	70.10-6	70.10-6	70.10-6
		°F-1	39.10-6	39.10-6	39.10-6	39.10-6
Flammability	DIN 4102	Building Material Class	B1 DIFFICULT to Ignite	B1 DIFFICULT to Ignite	B1 DIFFICULT to Ignite	B1 DIFFICULT to Ignite
Size	Width 600 mm length 1250 mm					
Thickness	2.5cm,3cm, 4 cm, 5cm					
Edge profile	Ship lap edge					
Standard	BS 3837: Part 2:1990 ASTM C 578-95					

